

DATA SHEET

DBV 2 Thermal Safety Relief Valve, insulated

DBV 2, insulated



DBV 2 with T-piece, insulated



Main Features

Application	Protection against overheating of a solid-fuel fired heat source w. no cooling heat exchanger.
Function	Feed and bleed valves are controlled by a thermostatic element; when the limit temperature is reached, both the valves open simultaneously; the bleed valve permits exit of overheated water from the heat source to sewer, the feed valve opens water inlet from the mains; when the temperature drops below the limit value, both the valves close.
Working fluid	Water, antifreeze fluid for heating systems.
Installation ^{1), 2)}	Vertical or horizontal, as close to an outlet from a heat source as possible, insulation can be fitted or removed even after the valve is installed.
Codes	16627 – DBV2, insulated 16863 – DBV2 with T-piece, insulated

1) When installed horizontally, the hot heating fluid outlet shall point downwards.

2) When installed vertically, the head shall not point downward.

Technical Data

Nominal diameter	DN 20
Pipe connection	G 3/4" outer
Connection to heat source	R 3/4" outer (conical)
Min. diameter of connected piping	DN 16
Nominal pressure	PN 6
Heating fluid max. working pressure	4 bar
Cold water max. working pressure	6 bar
Fluid max. working temperature	110 °C
Valve opening temperature	97 ± 2 °C
Max. cooling capacity* (stroke of both elements)	220 kW
Max. cooling capacity* (stroke of one element)	140 kW
K _{vs} at temp. of 110 °C – stroke of both elements	2 m ³ /h
K _{vs} at temp. of 110 °C – stroke of one element	1.3 m ³ /h

* Under these cooling water parameters, before the valve: 2 bar pressure, 15 °C temperature.

Weight

DBV2 and insulation	0.74 kg
DBV2, T-piece, insulation	1.18 kg

Materials

Valve housing	forged brass
Valve gate	forged brass
Valve head	nylon
Sealing O-rings	EPDM
T-piece	brass
Insulation	EPP RG 60 g/l

The valve is approved in compliance with the Directive 97/23/EC (PED) and meets the requirements for a device for dissipating excess heat by Art. 4.3.8.4 EN 303-5:2012. This is a STW device of Th type by EN 14597:2012. According to EN 303-5:2012, the valve is intended for boilers of max. 500 kW output, with up to 100 kW cooled output.

Thermal Safety Relief Valve must not be used to replace a heat source safety valve.

DATA SHEET

DBV 2 Thermal Safety Relief Valve, insulated

Dimensions

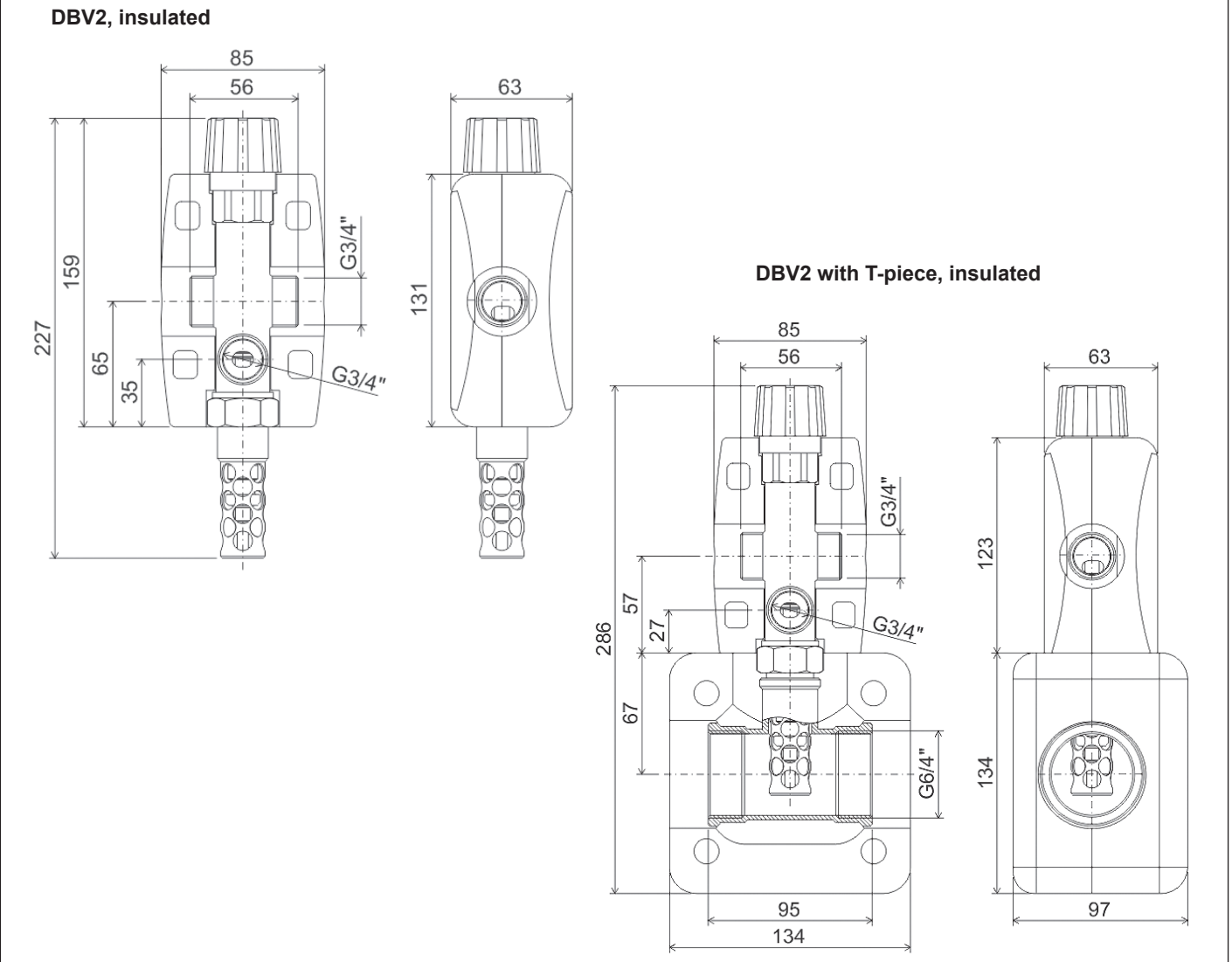

Connection diagram

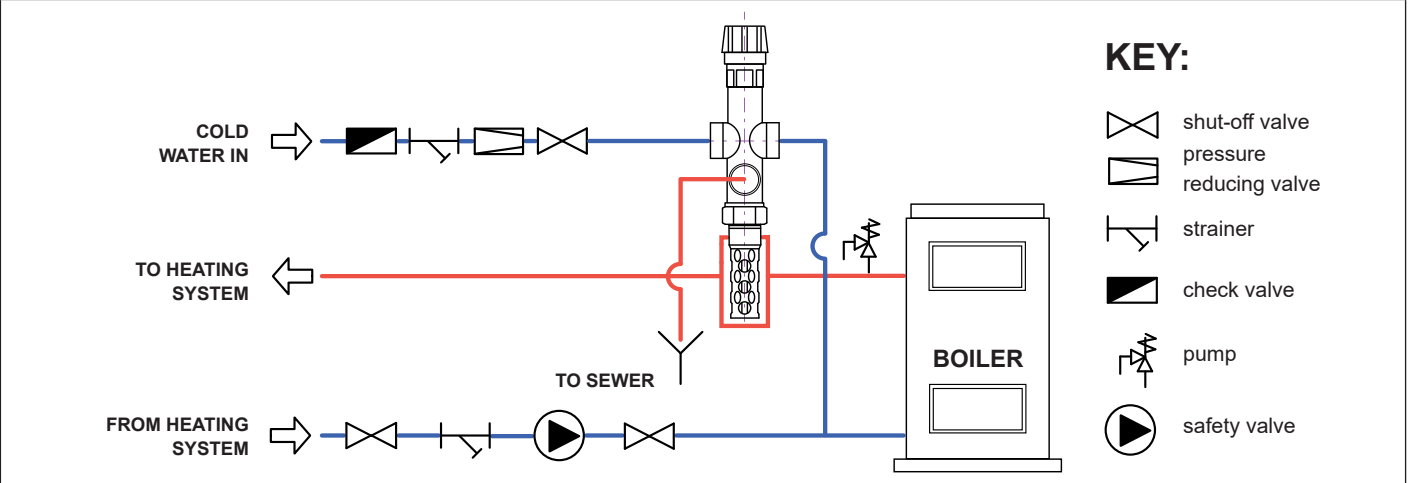

Before the assembly is finished, each valve gets its serial number and is tested. During testing a pressure test is performed, tightness of all its O-rings is verified as well as simultaneous opening of both the sections, the value of the opening temperature and stroke. The course of the test is recorded.